

Carony 16 wheelchair system

The **Carony 16** is a **wheelchair system** that lets you **transfer from wheelchair to car seat without lifting**. It offers **comfort** and **security** to the user.

The seat is the mobile part of the Carony that slides by carrying the user between the wheelbase and the swivel base. It offers several functions to ensure **good posture** and **relieve the pressure**.

The **Carony 16 system** has rear handles with brake and includes the possibility to raise the front of the seat and tilt the folder. It's as safe and comfortable as a standard car seat and it's as versatile and easy to use as a transport wheelchair.



Carony 16 main features

- Weight capacity: **120 kg**
- High quality 16" wheels with reflective stripes
- Suitable for people of all sizes, including small people and children
- **A single seat for the wheelchair and the vehicle**
- **Integrated push handles with brake**
- **Many comfort options and ergonomic functions**
- **Adjustable armrests**
- **Supports for the torso and thighs**
- **Integrated pneumatic pocket** which allows to **raise the cushion** to improve the comfort of the seat
- Improved stability
- Metal frame, gray color, black seat
- **Elegant design**

Wheelbase accessories

Anti-tip device
Puncture free wheels
Elevating leg support

Comfort accessories

Thigh and torso support
4 points shoulder harness
Universal elastic strap
2-point hip belt
Calf / heel supports
Headrest (cervical cushion)

SWIVEL BASE COMPATIBILITY					
TURNOUT	TURNY MANUAL	TURNY LOW VEHICLE	TURNY HD/ORBIT	TURNY EVO	6-WAY BASE
✗	✓	✗	✓ ³	✓ ³	✗

3. requires adapter plate with rails

Requires a swivel base for using in the vehicle. Recommended accessories: Tilda Tilt function: seating adjustments for pressure relief and comfort when using a swivel seat.



Address : BP19, 80490 Hallencourt, France

Tel : +33 (0)3 22 25 58 65 / Mobile : + 33 (0)6 45 72 46 90

contact@access-ability.eu
www.access-ability.eu

Models and dimensions

TOP VIEW

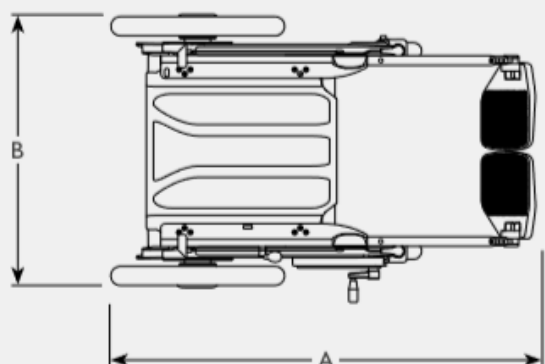

TOP VIEW

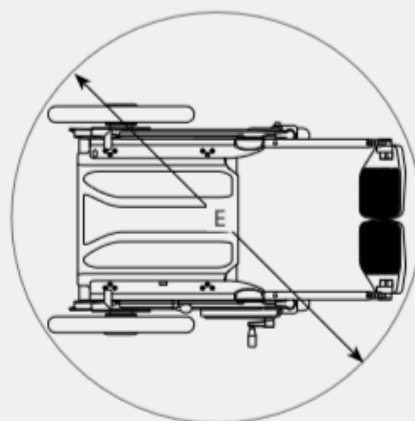

SIDE VIEW

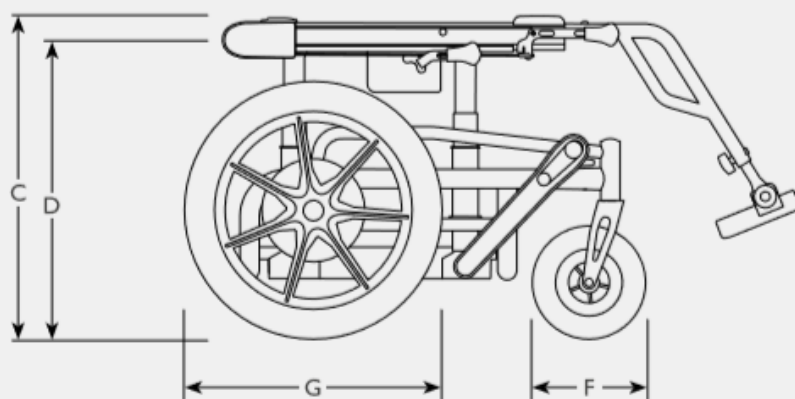

Carony 16 wheelchair system

Carony		Brake lever side	Length	Width	Height	Docking height	Turning radius	Front wheel diameter	Rear wheel diameter	Maximum user weight	Unit weight
		A	B	C	D	E	F	G			
103927	Carony 16*	both*	71	64	43-57	37-51	103	7"	16"	120	15.5
104072	Adapter plate with rails: Turny Evo										
104073	Adapter plate with rails: Turny HD/Orbit										

All weights and dimensions are given in kilograms and centimetres, and for reference only. *mount the brake lever on one of the two sides

To guarantee your safety Autoadapt products are designed and tested according to current directives and standards.

Contact us for a free quotation !



Address : BP19, 80490 Hallencourt, France

Tel : +33 (0)3 22 25 58 65 / Mobile : + 33 (0)6 45 72 46 90

contact@access-ability.eu
www.access-ability.eu